



TEAM DIGITAL

Improving the world of DCC

DCCBreak DCC Circuit Breaker

- > Short and over current protection
- > Adjustable shutdown current level
- > Adjustable turn on delay
- > 4 amp continuous operation
- > Very low track voltage drop
- > Output on/off control via DCC
- > Small size - 2.25" x 1.62"

Extra cost option

- > Connection for external fault indication
- > Connection for on/off control

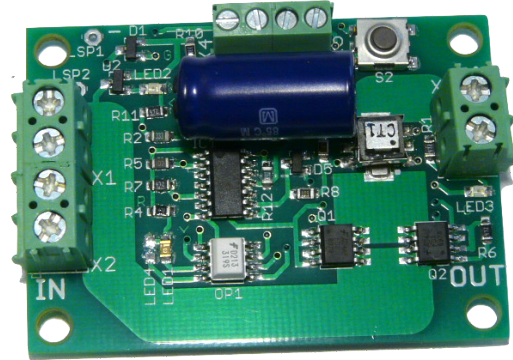

Description

The DCCBreak is designed to protect boosters from shutting down due to short circuits or over current conditions (fault). It also has some features that help to start "difficult loads" that may otherwise cause the booster problems. One type of "difficult load" is caused by the capacitors used in some decoders, typically with sound. When power is first applied to a capacitor, it appears like a short until it is charged.

The DCCBreak is intended to be used with 5 amp (or less) boosters. The maximum continuous operating current is 4 amps. The highest over current limit can be set to about 4.8 amps.

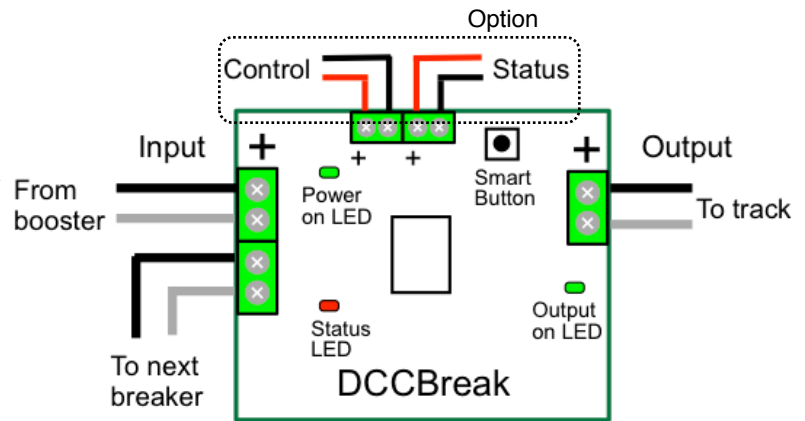

TEAM DIGITAL, LLC
 3111 Timber Valley Dr
 Kokomo IN 46902
 www.teamdigital1.com

1 Getting Started	3
1.1 LED Indicators	3
2 Operation	3
3 “Smart” Programming	3
4 Configuration Variables (CVs)	4
4.1 On/Off Control Address	4
4.2 Decoder Configuration	4
4.3 Current Limit	5
4.4 Time of over current	5
4.5 Time off after fault	5
4.6 Time before output on	5
4.7 Operations Mode Loco Address	5
5 Connections	5
6 Applications	6
7 Summary of Configuration Variables	6

1 Getting Started

The DCCBreak comes from the factory ready to use. The default current limit setting is 3.4 amps. Connect the DCCBreak input to a booster/command station and the output to the track section to be protected. Track sections should be insulated from each other. Be sure and maintain the correct polarity when connecting the DCC wiring. Since the DCCBreak is powered from the track, it draws current. Any block detectors should be installed on the output side of the DCCBreak.

The DCCBreak has a second input connector so that multiple DCCBreaks can be daisy chained together. Maximum wire gauge is 14.

Note: If you are using a Digitrax DCS51 set the current limit to 2.7 amps and the time of over current to 10 ms.

If you are using a NCE PowerCAB set the current limit to 2.3

amps and the time of over current to 15 ms. You may still need to make adjustments based your layout. See section 3.

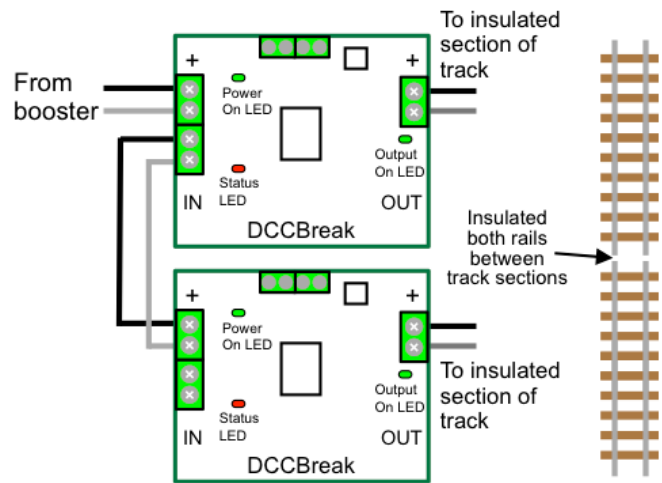

1.1 LED Indicators

Power On LED indicates power is applied to the input. The Status LED indicates when there is a fault and used for “Smart” programming. The Output On LED indicates power is applied to the track.

Note: It is normal for the Power On LED to flicker during a fault condition. However, if the Power On LED goes out during a fault, that means the booster shutdown instead of the DCCBreak. In this case you will need to decrease the current limit and perhaps the over current time. Also, the Output On LED will be faintly lit when there is no load on the output and the DCCBreak is commanded off.

2 Operation

The DCCBreaks monitors current flowing from its input to its output. If there is a fault caused by an over current or short condition the DCCBreak turns its output off and begins a sequence off turning its output on and off until the fault condition is removed. During a fault condition the output can be completely turned off by pressing the smart button or by the control input.

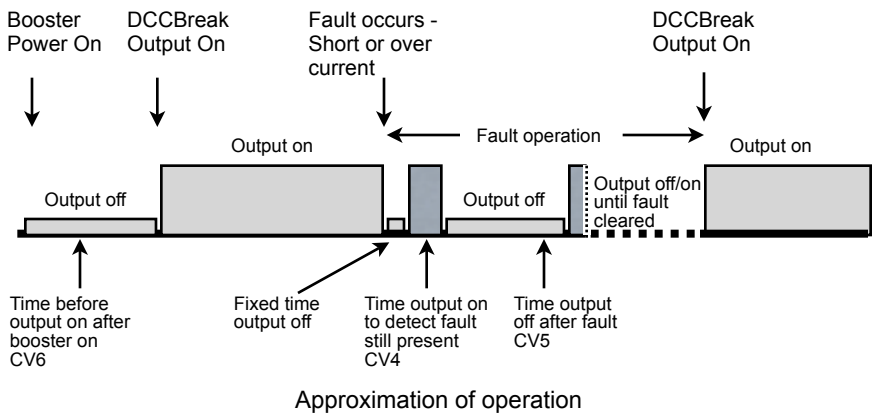

If there are several DCCBreaks on the layout, they can be programmed so that each has a different turn on time after the booster turns on. This prevents the booster from experiencing the total layout load current at power on.

The output of the DCCBreak can be turned on and off by issuing a turnout (switch) command or by the control input. This can be useful if you do not want sections of track to be powered all the time. Additionally it can be programmed so that when booster power is turned on the DCCBreak does not turn on it’s output until commanded. Note: If a fault is present the DCCBreak does not respond to any DCC commands.

3 “Smart” Programming

“Smart” programming is a term used to describe an easy way to program Configuration Variables (CVs). The throttle is used to issue switch or accessory commands just like controlling switches (turnouts).

To program in “Smart” mode, connect the DCCBreak input to the booster/command station. Turn on power and wait for the output to turn on. Press the “Smart” program button and hold it down for approximately one second until the Status LED starts to flash. Then release it. The DCCBreak is now ready to be programmed via turnout commands.

Smart Programming Summary			
#Flashes	Description	Default	t or c
<i>To start - Press the “Smart” button until the Status LED starts to flash</i>			
1	Over current limit (see current limit table)	4	accept
2	Time(ms) of over current (fault) before output off	25	accept
3	Time(x262ms) of output off after fault	8	accept
4	Time(x262ms) before output on after booster on	4	accept
5	On/Off Control address	900	accept

Using the throttle select the switch address or accessory number you want for the over current limit. For example, to set the current limit to 2.3 amps issue an address of two (2). (See the current limit table).

Current Limit Table			
Number	Current Limit	Number	Current Limit
1	~ 1.6 Amps	5	~ 3.8 Amps
2	~ 2.3 Amps	6	~ 4.3 Amps
3	~ 2.7 Amps	7	~ 4.8 Amps
4	~ 3.4 Amps (default)	-	

The Status LED now flashes twice with a pause and then repeats indicating that the time of over current is ready to be programmed.

Note: If you are just changing the current limit, exit “Smart” programming by pressing and holding the button until the Status LED stops flashing.

As you progress through the “Smart” programming steps, the Status LED flashes the number of times indicating which step is ready to be programmed.

Switch (Turnout) Terminology		
This manual	throw or t	close or c
Digitrax	throw or t	close or c
NCE	reverse or OFF or 2	normal or ON or 1
Lenz	-	+
MRC	OFF	ON

At any time you can exit “Smart” mode by pressing the button until the Status LED stops flashing.

4 Configuration Variables (CVs)

The DCCBreak supports **Operations (Ops) Mode** programming. To program in Ops mode or “programming on the main” holding down the Smart button just before power is turned on. When the Status LED begins to flash rapidly release the button. This temporarily sets the DCCBreak in ops mode until power is turned off. **When using ops mode to change CV values, the DCCBreak does not recognize the new values of CVs until power is turned off and then back on.** The default address is 1 and can be changed if desired (CV31). **This is a loco address, so be careful when using this feature.**

Reset the DCCBreak to factory defaults.

To “reset” the DCCBreak to factory defaults, turn power on. Then press the “Smart” button and continue to hold the button down (at least 10 seconds) until the Status LED (red or yellow) is rapidly flashing. At first the LED will flash at a slower rate and then flash rapidly.

4.1 On/Off Control Address

CV1 - Control address, value 0 to 255.

CV9 - Control address adder, 0 to 9.

The default turnout address is 900 (CV1 = 132, CV9 = 3).

These CVs determine the address that allows the DCCBreak to be turned off and on by a turnout (switch) command via DCC. By issuing a turnout throw command with this address the output of the DCCBreak is turned off. To turn it on issue a close command. Note: This does not function during a fault condition.

The address is constructed with two CVs, an address and an address adder. If an address greater than 255 is needed then the address adder value will be greater than zero. Otherwise the address is set by the address value only.

The address adder value represents a number that is added to the address value to give the required address. The following table shows the CV value to use for the adder. For easier programming see “Smart” Programming.

Address Adder										
CV Value	0	1	2	3	4	5	6	7	8	9
ADD	0	256	512	768	1024	1280	1536	1792	2048	2304

4.2 Decoder Configuration

CV29 - Configuration.

This CV determines the configuration.

Option 1 - Off at power on. The DCCBreak output will be off at power on until commanded to be on. It can be turned on by issuing a close turnout command with the control address or by the control input. This option disables CV6 (time before output on after booster on).

4.3 Current Limit

CV3 - Current limit number, value of 1 to 7.
 The default current limit is 3.4 Amps. (CV3 = 4).
 This CV determines the current at which the DCCBreak considers to be a fault. Adjust the current limit to something less than the current rating of the booster it is protecting. Note -The CV value is not the same as the actual current limit.

Current Limit Table			
CV Value	Current Limit	CV Value	Current Limit
1	~ 1.6 Amps	5	~ 3.8 Amps
2	~ 2.1 Amps	6	~ 4.3 Amps
3	~ 2.7 Amps	7	~ 4.8 Amps
4	~ 3.4 Amps (default)	-	

4.4 Time of over current

CV4 - Time in milliseconds (0.1 seconds) of over current, value of 1 to 255.
 The default time is 25ms. (CV4 = 25).
 This CV determines the time the DCCBreak allows an over current (fault) condition before it turns off the output. The over current limit is defined by CV3.
 Over current time is somewhat of a compromise. If there is a short on the track it is desirable to turn off power immediately to avoid the booster shutting down or damage to a locomotive. On the other hand, if there are several sound locomotives on the track, they present what looks like a short (high current spike) when power is first turned on.
 Values greater than 100 ms are not recommended because of booster shut down times.

4.5 Time off after fault

CV5 - Number times .256 seconds, value of 1 to 255.
 This CV determines the time the DCCBreak keeps the output off after a fault before it turns the output back on. Once it turns on, it will turn back off if the fault is still present.
 Example: 8 x .256 ~ 2 seconds

4.6 Time before output on

CV6 - Number times .256 seconds, value of 1 to 255.
 This CV determines the time the DCCBreak waits to turn the output on after it is powered on (after the booster turns on). Set different delay times for each DCCBreak to prevent the booster from experiencing the total layout load current at power on.
 Example: 4 x .256 ~ 1 seconds

4.7 Operations Mode Loco Address

CV31 - Ops mode address, a value of 1 to 127. Default is one (1).
 This CV sets the operations mode program address. Program the DCCBreak just like you would a loco in ops mode. This is a loco 2 digit address and therefore must be unique among locomotive addresses. If the “Smart” program button is pressed when power is turned on, ops mode is enable until power is removed.

5 Connections

Connect the booster output to the DCCBreak input.
 Connect the DCCBreak output to the track.

The Status option output is used to indicate when a fault is present. It can be used to drive an external LED or interface to a device like Team Digital’s SRC16. See the applications section for more details.

The control option input is used to turn on and off the output. If the output is off due to the control input than the output can not be turned on by a turnout command via DCC. The control input over rides control via DCC. It will also turn off the output during a fault condition.

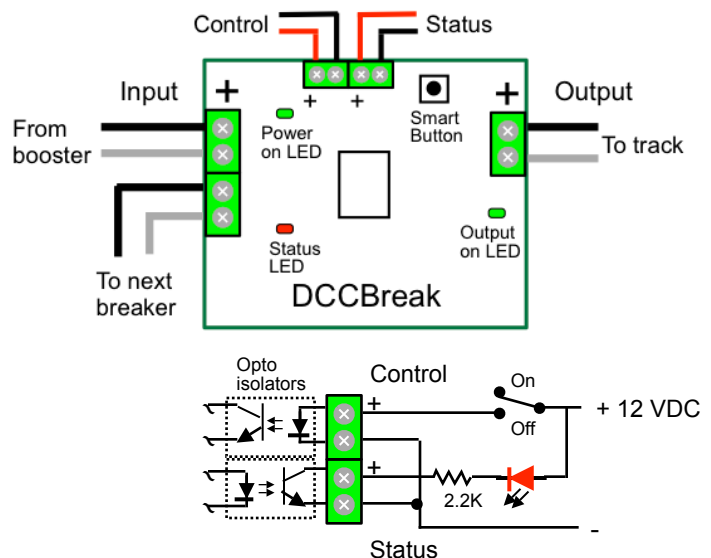

6 Applications

By connecting a DCCBreak(s) to a Team Digital SRC16, status and control could be handled in one or more remote locations via the serial bus. A typical connection is shown.

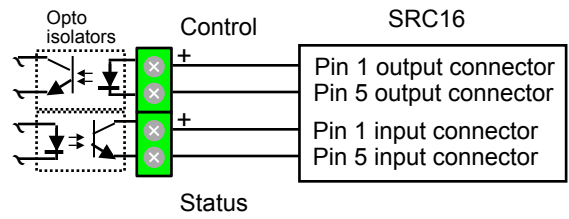

7 Summary of Configuration Variables

CV#	Function	Default Value	User Value
1	Control Address (CV1 & CV9 default = 900)	132	
2	reserved	-	
3	Over current limit	4	
4	Time(ms) of over current (fault) before output off	25	
5	Time(x262ms) of output off after fault	8	
6	Time(x262ms) before output on after booster on	4	
7	Manufacturer Version No.	-	
8	Manufacturer ID	25	
9	Control Address Adder	3	
10	reserved	-	
-	reserved	-	
29	Configuration	0	
30	reserved	-	
31	Ops Mode Loco Address	1	
32	reserved	-	
33	reserved	-	
34	reserved	-	